

Skywire™ BeagleBone Black Cape Data Sheet

NimbeLink Corp

Updated: July 2016



NimbeLink Corp. 2016. All rights reserved.

NimbeLink Corp. provides this documentation in support of its products for the internal use of its current and prospective customers. The publication does not create any other right or license in any party to use any content contained in or referred to in this document and any modification of this document is not permitted.

Efforts are made to ensure accuracy, typographical and other errors may exist in this document. NimbeLink reserves the right to revise its products and to modify this and any other product documentation at any time.

NimbeLink products are sold subject to its published Terms and Conditions, subject to any separate terms agreed with its customers. No warranty is extended by publication of this documentation, including, but not limited to, implied warranties of merchantability, fitness for a particular purpose and non-infringement.

BeagleBone Black is a registered trademark of Digi International, Inc

NimbeLink is a registered trademark, and Skywire is a trademark, of NimbeLink Corp. All trademarks, service marks and similar designations mentioned in this document are the property of their respective owners.

Table of Contents

- 1. INTRODUCTION**
 - 1.1 OVERVIEW
 - 1.2 PRODUCT DESCRIPTION
 - 1.3 ORDERABLE PARTS
 - 1.4 ADDITIONAL RESOURCES
- 2. TECHNICAL SPECIFICATIONS**
 - 2.1 BLOCK DIAGRAM
 - 2.2 PINS USED
 - 2.3 BEAGLEBONE COMPATIBILITY
 - 2.4 FEATURES AND SPECIFICATIONS
 - 2.4.1 Specifications*
 - 2.4.1.1 Mechanical Specifications*
 - 2.4.1.2 Electrical Specifications*
 - 2.4.1.3 Power Requirements*
 - 2.4.1.4 Antenna Specifications*
 - 2.4.2 Features*
 - 2.4.2.1 Skywire Cellular Modem*
 - 2.4.2.2 USB HUB*
 - 2.4.2.3 MUX*
 - 2.4.2.4 CAN*
 - 2.4.2.5 XBEE Socket*
 - 2.4.2.6 EEPROM*
 - 2.4.2.7 Connectors, switches, and Status LEDs*

1. Introduction

1.1 Overview

This document is the data sheet for the Skywire™ Beagle Bone Black Cape. Throughout the document Skywire™ Beagle Bone Black Cape will often be referred to as 'the cape,' although it may be referred to by its full name.

The NimbeLink Skywire™ modem is available with bundled data plans from leading cellular carriers.

The Skywire™ cellular modem and antennas are sold separately.

Make sure you check the Nimbelink's Skywire™ Beaglebone Black Cape product page for the most up to date information.

1.2 Product Description

Connect the Beaglebone Black development platform to the Internet of Things (IoT) quickly and easily with Nimbelink's Skywire™ Beaglebone Black Cape. Whether you are a hobbyist or a developer preparing a product for launch, Nimbelink's cape and your choice of NimbeLink Skywire™ plug-in cellular modems will provide the cellular connectivity you need. Cellular connectivity is just one of the capabilities Nimbelink's Beaglebone Black Cape offers including:

- Built-in CAN transceivers for equipment and vehicle data connections
- Built-in socket for XBee modules for wireless communications
- Nimbelink's EVDO and LTE Skywire™ modems provide GPS with a high speed cellular connection
- Skywire's™ Verizon ODI certification eliminates the long wait for certification
- Two additional USB-A receptacles add flexibility
- Nimbelink's optional bundled, no-contract cellular plans are easy and affordable

1.3 Orderable Parts

Table 1.1 Orderable Parts				
Number	Description	Manufacturer	Carrier	Network Type
NL-AB-BBBC	Skywire™ Beagle Bone Black Cape	Nimbelink		
NL-SW-1XRTT-V	Skywire™ 1xRTT Cellular Modem without data plan. 2G Modem.	Nimbelink	Verizon	CDMA 1xRTT
TG.30.8113	Primary & Diversity Cellular Antenna	Taoglas		
NL-SW-EVDO-V	Skywire™ EVDO Cellular Modem without Data plan. 3G Modem.	Nimbelink	Verizon	CDMA EVDO
MA.301.A.AB.00	3G Primary Antenna, GPS/GLONASS	Taoglas		
1	Antenna for Skywire™ EVDO*			

*Antenna is a dual cellular & GPS antenna

1.4 Additional Resources

- Nimbelink's Skywire™ [Beaglebone Black Cape Product Page](#)
- Nimbelink's Skywire™ [Beaglebone Black Cape Device Tree Overlay](#)
- Nimbelink's Skywire™ [Beaglebone Black Cape Schematic](#)
- Nimbelink's Skywire™ [Beaglebone Black Cape Github](#)
- Nimbelink's [Skywire™ 2G 1xRTT Product Page](#)
- Nimbelink's [Skywire™ 3G CDMA/EVDO Product Page](#)
- Telit's [CE910 Hardware User Guide](#)
- Telit's [DE910 Hardware User Guide](#)

2. Technical Specifications

1.5 Block Diagram

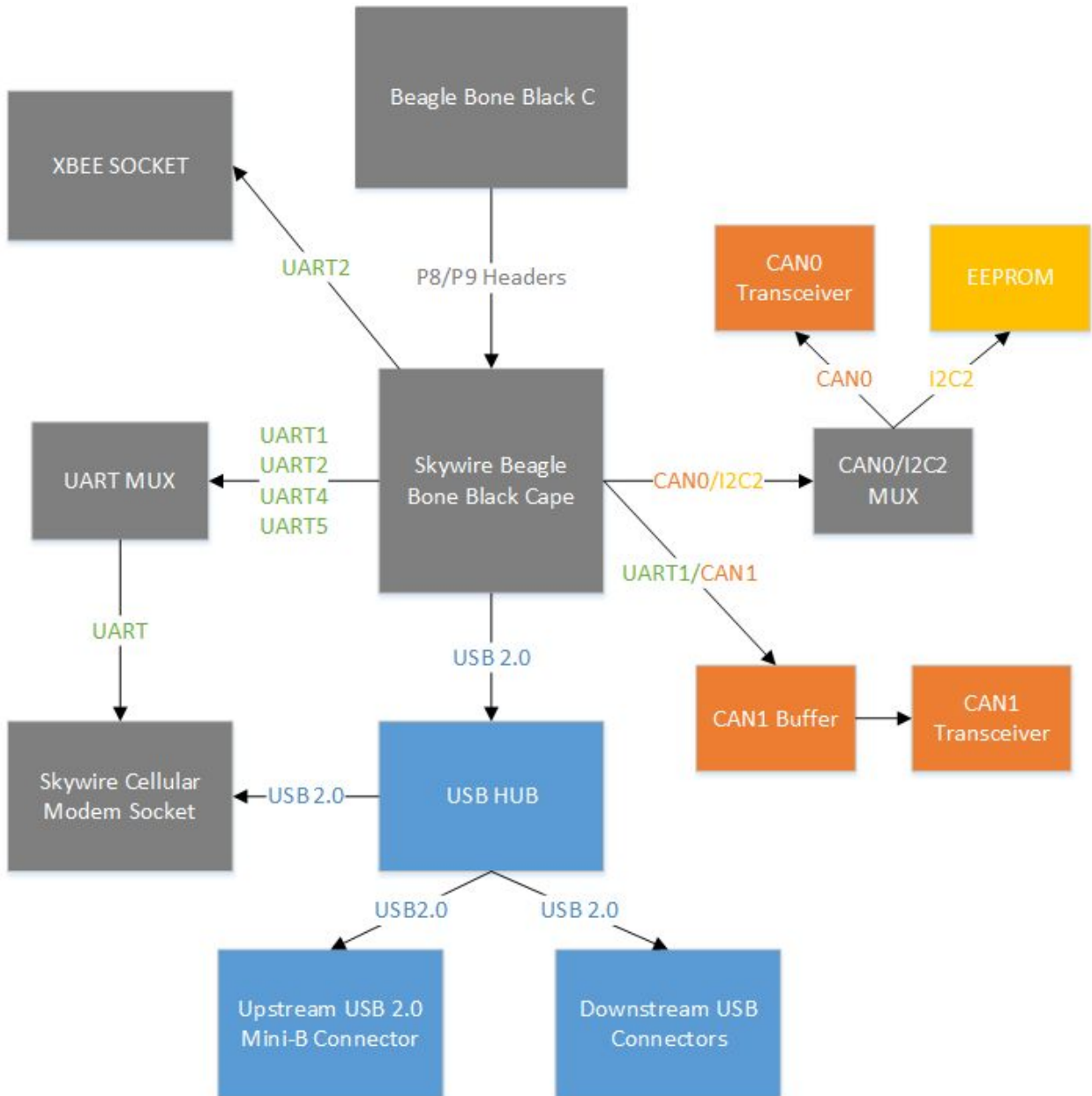

1.6 Pins used

The cape uses up to 29 pins (I/O Pins, VCC, GND, and reset pins) in various configurations, although at any one time the cape will likely be using 4-10 I/O pins plus the 15 VCC, ground, and reset pins.

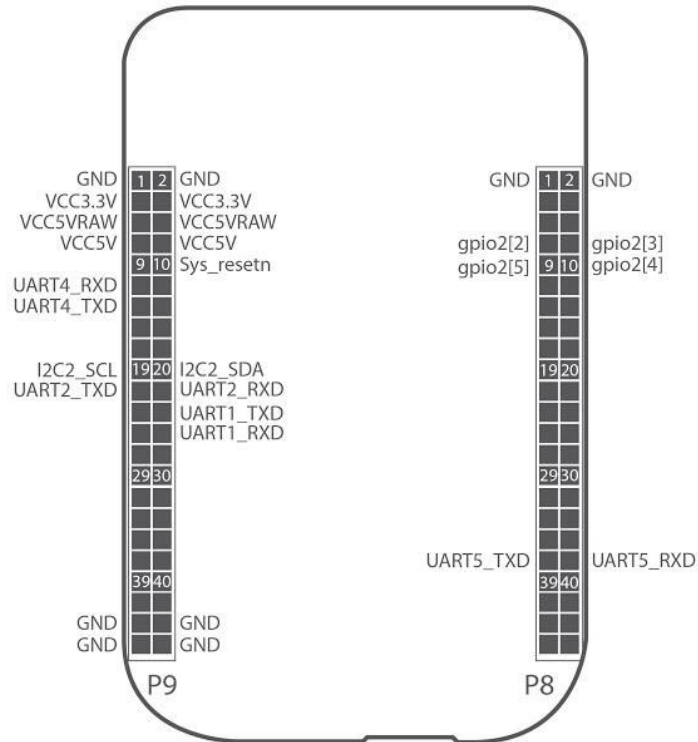

PIN Name	Header	Pin Number
CAN0 EN	8	7
SKY ON-OFF	8	8
CAN1 EN	8	9
SKY DTR	8	10
UART5 TX	8	37
UART5 RX	8	38
UART4 RX	9	11
UART4 TX	9	13
SCL2	9	19
SDA2	9	20
UART2 TX	9	21
UART2 RX	9	22
UART1 TX	9	24

1.7 Beaglebone Compatibility

Nimbelink's Skywire™ Beaglebone Black Cape was designed around the Beaglebone Black platform and has not been verified on the original Beaglebone.

1.8 Features and Specifications

1.8.1 Specifications

1.8.1.1 Mechanical Specifications

Table 2.2: Skywire™ Beaglebone Black Cape Mechanical Specifications	
Mechanical Size	3.95" X 2.15"
Layers	4
PCB Thickness	.062"
RoHS Compliant	Yes

1.8.1.2 Electrical Specifications

Table 2.3: Skywire™ Beaglebone Black Cape Electrical Specifications	
Power	5V via P9
	4V via U1
	3.3V via P9
I/O Voltage	3.3V
Max Current Usage 5V	1.6A
Max Current Usage 3.3V	130 mA
Beaglebone 5V Input Typical Current Usage in (No USB devices, Skywire™ active, Beaglebone powered)	25 mA
Pins used	29
LED Indicators	See Table 2.9
Connectors	See Table 2.8
EEPROM Support	Yes

1.8.1.3 Power Requirements

The Skywire™ Beagle Bone Black Cape requires 5V and 3.3V inputs from the Beagle Bone Black header P9.

The Skywire™ Cellular Modem will regularly consume high amounts of current (up to 750 mA) from the adapters power supply. Additionally the USB hub is capable of supplying up to 500mA per downstream port.

It is recommended to have at least 2.5A of available source current available for the adapter board to provide power for the Skywire™ Cellular Modem and the USB hubs connected devices.

1.8.1.4 Antenna Specifications

Onboard the Skywire™ are three U.FI to PCB mound SMA cables that allow for the full feature set of the Nimbelink Skywire™ modems to be utilized. For cellular only communication it is recommended to use a Taoglas [TG.30.8113](#) antenna. If the user is using both cellular and GPS use a Taoglas [MA.301.A.AB.001](#).

1.8.2 Features

Nimbelink's Skywire™ Beaglebone Black Cape is designed to be an adaptable cellular gateway for the Beagle Bone Black C. The cape enables diverse connectivity options by including a Skywire™ Cellular Modem socket for cellular/GPS connections, a USB hub with two USBA connections, two can transceivers, and an XBee compatible socket.

1.8.2.1 Skywire™ Cellular Modem

Nimbelink's Skywire™ cellular modems are the fastest way to provide cellular connectivity for machine-to-machine devices and speed them to market. The Pre-certified Skywire™ is the smallest plug-in cellular modem on the market, making it quicker and easier to deploy than chip down solutions, external modems, or solder-in modules. It uses a standard XBee form factor and it's pre-certification to eliminate months of delays and tens of thousands of dollars in cost for required certifications.

The capes Skywire™ socket allows for the Skywire™ cellular modem to communicate with the Beaglebone Black development kit over UART or USB connections. The Skywire's™ standard XBee form factor allows for compatibility across all of the Skywire™ product line and interchangeability between 2G, 3G, and 4G cellular technologies.

Table 2.4: Skywire™ Cellular Modem Operating Parameters		
Default Skywire™ UART Baud Rate		115200 bps
Skywire™ I/O Voltage range		1.65V-5.5V
Skywire™ Power Consumption	Active Call(max)	750 mA
	Normal	29 mA
	Power Saving	1.1 mA
Skywire™ Input Voltage		4.0 V
Communication options		UART, USB
Temperature Range		-40 to 85C
Dimensions		47mm x 82mm x 25mm

1.8.2.2 USB HUB

Onboard the Skywire™ Beaglebone Black cape is a Microchip USB2514 four port USB 2.0 hub supporting LS/FS/HS USB connections. The USB hub is used to provide additional USB ports for the Beaglebone Black while allowing for direct communication between the Beaglebone Black and the Skywire™ Cellular modem.

Connect the capes upstream USB hub port, J3 (Mini-B USB connector), to the Beaglebone's USB-A downstream port to connect the Beaglebone to the capes USB hub.



Figure 2-2 Cape to Beaglebone USB Connection

Each downstream port on the capes USB hub is capable of supplying up to 500 mA of current to the downstream port.

1.8.2.3 MUX

The cape has two MUX's to allow for multiple operating modes and a large range of cape compatibility. The connection configuration truth tables are shown in tables 2.4 and 2.5.

Table 2.5: UART MUX (U7) Channel Connection Truth Table

J8 Jumper IO Level		Skywire™ UART Connection
MUX	MUX	S0
OE#	S1	

L	L	L	UART4 (Default Connection)
L	L	H	UART2
L	H	L	UART1
L	H	H	UART5

Table 2.6: CAN MUX (U10) Channel Connection Truth Table

J8 Jumper IO Level	Data Connection
S0	
L	I2C2 (Default Connection)
H	CAN0

1.8.2.4 CAN

The cape has dual CAN bus capabilities. CAN0 and CAN1 both have a TI SN65HVD234D 3.3V CAN transceiver connected. Before connecting to the capes can system make sure the CAN transceivers can support your CAN bus system. Both of the CAN transceiver output lines are connected to J7 (as shown below). J7 is a 2x3 .1" pitch non populated header that the user can solder leads on to connect to the CAN bus.

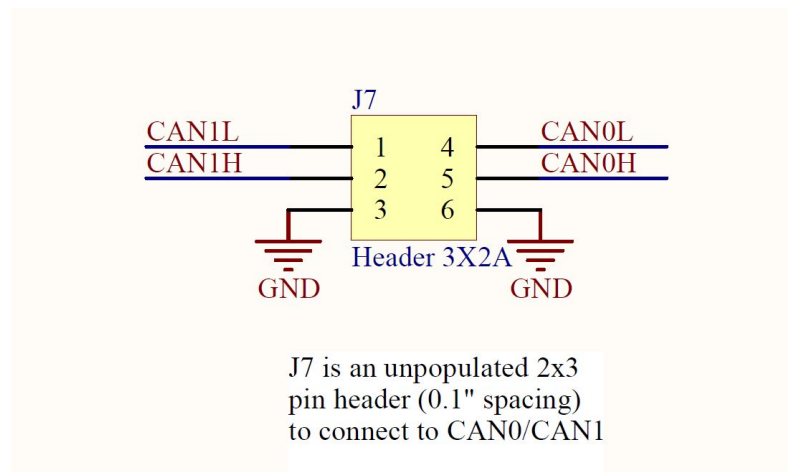

Enabling CAN0

CAN0 is connected to its transceiver (U8) through MUX (U10) to prevent CAN0 and I2C2 from interfering with each other. To enable data transmission to the CAN0 transceiver a jumper must be placed between J8-4 and J8-10. This will cause the MUX (U10) to route the connection to the CAN0 transceiver. U8 has an option to enable or disable the transceiver by toggling pin 5. By default this pin is always enabled. To control the enable signal via GPIO a 0 ohm 0603 resistor should be soldered R46.

To enable CAN0 in the Device Tree please see the tutorial provided by Embedded Things [here](#).

Disabling CAN1

CAN1 is enabled by default in the device tree overlay. CAN1 is connected to its transceiver (U9) through a buffer (U11) to prevent CAN1 from interfering with UART1 when the I/O is in UART mode. By default data transmission is enabled to CAN1s transceiver. To disable data transmissions to the CAN1 transceiver place a jumper between J8-3 and J8-9 to enable the buffer. The can transceiver U9 has an option to enable or disable the transceiver by toggling pin 5. By default this pin is always enabled. To control the enable signal via GPIO a 0 ohm 0603 resistor should be soldered R28.

1.8.2.5 XBEE Socket

On board the cape is an XBee compatible socket (J14) for XBee form factor devices. The Socket connects to UART2, 3.3V, and Ground as shown below.

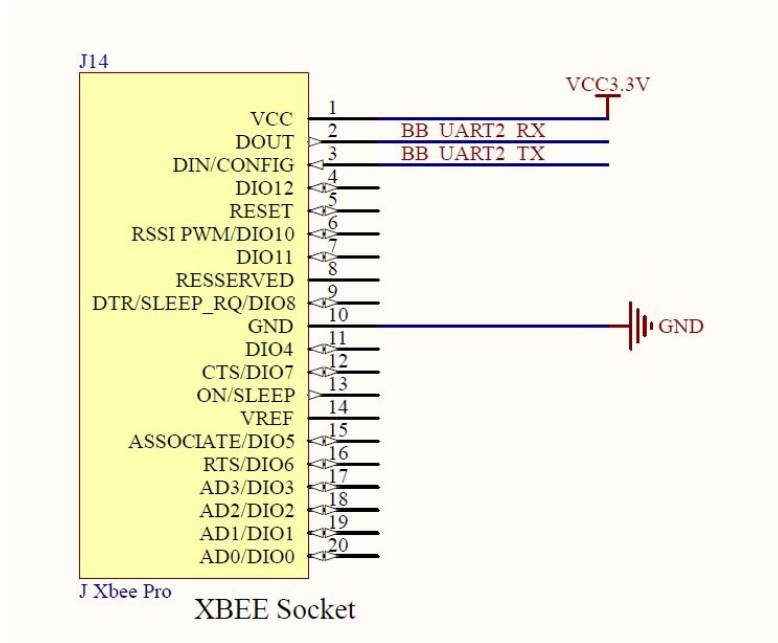

The socket is designed to accommodate XBee form factor devices up to 1.3" long by 0.95" wide.

1.8.2.6 EEPROM

The cape has its own EEPROM containing the boards EEPROM information per the Beaglebone EEPROM Data Format Revision A1. By default the EEPROM has write protection enabled to protect the EEPROM from data corruption.

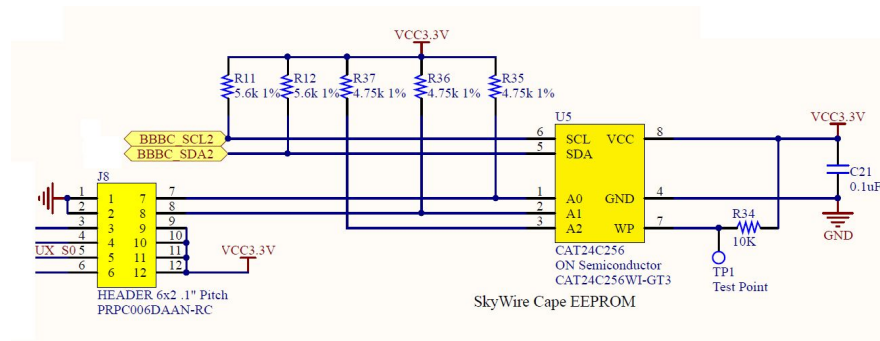

The address of the EEPROM is set via jumpers J8-1/J8-7 and J8-2/J8-8 on the J8 header as shown below.

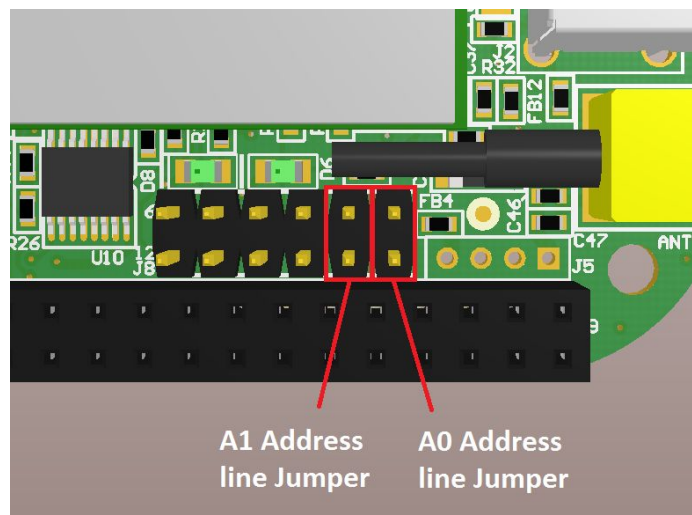

Table 2.7: EEPROM Address Configuration

Address	A2	A1	A0
0x54	High	Low	Low
0x55	High	Low	High
0x56	High	High	Low
0x57 (Default Address)	High	High	High

1.8.2.7 Connectors, switches, and Status LEDs

Table 2.8: Connectors and Switches	
Connector Name	Description
Ant1	PCB Mount SMA to U.FI cable for Skywire™ GPS antenna
Ant2	PCB Mount SMA to U.FI cable for Skywire™ diversity antenna
Ant3	PCB Mount SMA to U.FI cable for Skywire™ primary antenna
J1	4V current sensing port
J2	Downstream USB-A receptacle
J3	Upstream Mini-B USB receptacle
J4	Downstream USB-A receptacle
J5	Downstream 4 pin USB breakout header
J6	Skywire™ Cellular Modem XBee socket
J7	CANBUS header
J8	Operating mode selection pins
J14	XBee socket for 3.3V XBee devices
P8	Beaglebone P8 Header
P9	Beaglebone P9 Header
SW1	Reset Switch

Onboard the cape is nine status LEDs as shown in table 2.8

Table 2.9: Status LEDs	
LED	Function
D2	5V Power Indicator
D3	4V Power Indicator
D4	USB Power Indicator
D6	USB PORT4 Power Indicator, Not Populated
D8	USB PORT1 Power Indicator, Not Populated
D10	USB PORT2 Power Indicator, Not Populated
D13	USB PORT3 Power Indicator, Not Populated
D14	Skywire™ Status LED
D16	USB High Speed Indicator

